



VP50 FE

WHY RAMEX TROLLEY › PERCHÈ UN CARRELLO RAMEX

■ SAVE TIME	■ RISPARMIO DI TEMPO
■ SAVE MONEY	■ RISPARMIO DI DENARO
■ TOP QUALITY MATERIALS	■ MATERIALI DI ALTA QUALITÀ
■ VANGUARD TECHNOLOGY	■ TECNOLOGIA ALL'AVANGUARDIA
■ EFFICIENCY IN DAILY WORK	■ EFFICIENZA NEL LAVORO QUOTIDIANO
■ 100% MADE IN ITALY	■ MADE IN ITALY 100%

WHERE TO USE › DOVE UTILIZZARLO



TECHNICAL FEATURES › CARATTERISTICHE TECNICHE

Code Codice	VP 50 FE
Material Materiale	Powder coated steel Ferro verniciato
Dimensions Dimensioni	1.6 x 2.9 x 3.6 ft / 500 x 900 x 1100 mm
Weight Peso	8 Kg
Compatibility Compatibilità	Suitable to apply all the AVM 98XX series and AVM 9002 (not available for AVM 9850 and AVM 9851)

DIMENSIONAL DRAWING › DISEGNO DIMENSIONALE

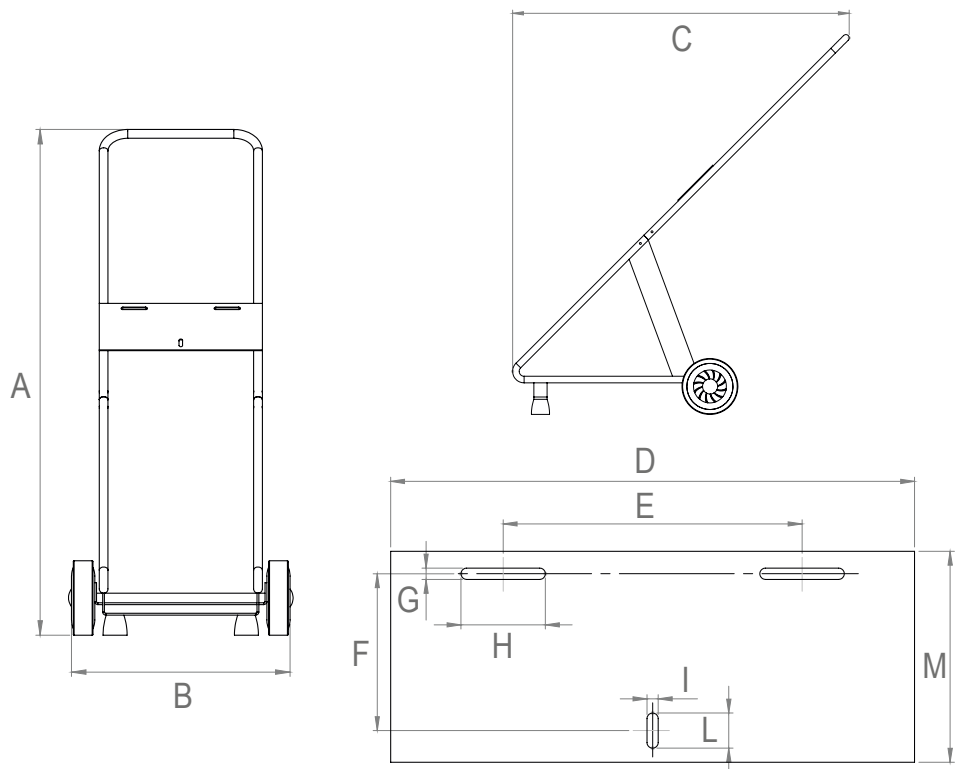

ART.	A	B	C	D	E	F	G	H	I	L	M
VP50 FE	1100 mm	500 mm	900 mm	350 mm	215 mm	115 mm	12 mm	65 mm	12 mm	25 mm	150 mm



On request
Su richiesta

RAMEX

