



# HR1100 400

## WHY RAMEX HOSE REELS , PERCHÈ UN AVVOLGITUBO RAMEX

- |                            |                                    |
|----------------------------|------------------------------------|
| ■ SAVE TIME                | ■ RISPARMIO DI TEMPO               |
| ■ SAVE MONEY               | ■ RISPARMIO DI DENARO              |
| ■ INCREASED SAFETY         | ■ SICUREZZA SUL LAVORO             |
| ■ LONG HOSE DURABILITY     | ■ INCREMENTA LA DURATA DEL TUBO    |
| ■ EFFICIENCY IN DAILY WORK | ■ EFFICIENZA NEL LAVORO QUOTIDIANO |
| ■ 100% MADE IN ITALY       | ■ MADE IN ITALY 100%               |

## WHERE TO USE , DOVE UTILIZZARLO



## PROPER USE , CORRETTO UTILIZZO



1



2



3



4

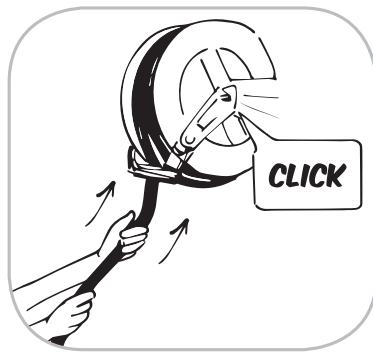

5



6

RAMEX

video



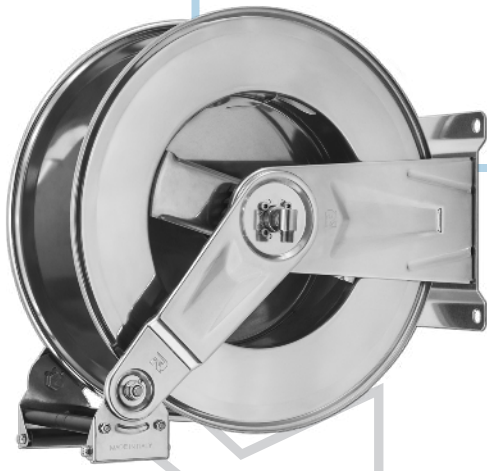

# HR1100 400

## TECHNICAL FEATURES › CARATTERISTICHE TECNICHE

### HR1100 400 AISI 304

<b>Admitted diameters</b> Diametri ammessi	1/4" - 3/8" - 1/2"
<b>Hose lenght in meters</b> Lunghezza tubo	Up to 65.6 ft 1/2" Fino a 20 mt 1/2"
<b>Working pressure</b> Pressione lavoro	Up to 5800 psi / Fino a 400 bar
<b>Working Temperature</b> Temperatura lavoro	140°C - 280°F *
<b>Inlet thread size</b> Connessione Ingresso	1/2" M
<b>Outlet thread size</b> Connessione uscita	1/2" F
<b>Weight</b> Peso	18 kg
<b>Packing size</b> Dimensione imballo	280x600x550 mm
<b>Raw material sides and roll</b> Materiali costruttivi rullo e fiancate	AISI 304
<b>Raw material shaft</b> Materiali costruttivi perno	AISI 303
<b>Raw material swivel joint</b> Materiali costruttivi giunto	AISI 303
<b>Raw material main spring</b> Materiale molla principale	Carbon Steel Acciaio al carbonio
<b>Can be used to transfer</b> Adatto all'utilizzo con	Water / Acqua
<b>Included Accessories</b> Accessori inclusi	Hose bumper (1/4", 3/8" o 1/2") and nipple (3/8" o 1/2") Palla finecorsa (1/4", 3/8" o 1/2") e nipplo (3/8" o 1/2")

### HR1100 400 FE

<b>Admitted diameters</b> Diametri ammessi	1/4" - 3/8" - 1/2"
<b>Hose lenght in meters</b> Lunghezza tubo	Up to 65.6 ft 1/2" Fino a 20 mt 1/2"
<b>Working pressure</b> Pressione lavoro	Up to 5800 psi / Fino a 400 bar
<b>Working Temperature</b> Temperatura lavoro	140°C - 280°F *
<b>Inlet thread size</b> Connessione Ingresso	1/2" M
<b>Outlet thread size</b> Connessione uscita	1/2" F
<b>Weight</b> Peso	18 kg
<b>Packing size</b> Dimensione imballo	280x600x550 mm
<b>Raw material sides and roll</b> Materiali costruttivi rullo e fiancate	Carbon Steel Acciaio al carbonio
<b>Raw material shaft</b> Materiali costruttivi perno	Carbon Steel Acciaio al carbonio
<b>Raw material swivel joint</b> Materiali costruttivi giunto	AISI 303
<b>Raw material main spring</b> Materiale molla principale	Carbon Steel Acciaio al carbonio
<b>Can be used to transfer</b> Adatto all'utilizzo con	Water / Acqua
<b>Included Accessories</b> Accessori inclusi	Hose bumper (1/4", 3/8" o 1/2") and nipple (3/8" o 1/2") Palla finecorsa (1/4", 3/8" o 1/2") e nipplo (3/8" o 1/2")

### HR1100 400 AISI 316

<b>Admitted diameters</b> Diametri ammessi	1/4" - 3/8" - 1/2"
<b>Hose lenght in meters</b> Lunghezza tubo	Up to 65.6 ft 1/2" Fino a 20 mt 1/2"
<b>Working pressure</b> Pressione lavoro	Up to 5800 psi / Fino a 400 bar
<b>Working Temperature</b> Temperatura lavoro	140°C - 280°F *
<b>Inlet thread size</b> Connessione Ingresso	1/2" M
<b>Outlet thread size</b> Connessione uscita	1/2" F
<b>Weight</b> Peso	18 kg
<b>Packing size</b> Dimensione imballo	280x600x550 mm
<b>Raw material sides and roll</b> Materiali costruttivi rullo e fiancate	AISI 316
<b>Raw material shaft</b> Materiali costruttivi perno	AISI 316
<b>Raw material swivel joint</b> Materiali costruttivi giunto	AISI 316
<b>Raw material main spring</b> Materiale molla principale	Carbon Steel Acciaio al carbonio
<b>Can be used to transfer</b> Adatto all'utilizzo con	Water / Acqua
<b>Included Accessories</b> Accessori inclusi	Hose bumper (1/4", 3/8" o 1/2") and nipple (3/8" o 1/2") Palla finecorsa (1/4", 3/8" o 1/2") e nipplo (3/8" o 1/2")

### HR1100 400 CA

<b>Admitted diameters</b> Diametri ammessi	1/4" - 3/8" - 1/2"
<b>Hose lenght in meters</b> Lunghezza tubo	Up to 65.6 ft 1/2" Fino a 20 mt 1/2"
<b>Working pressure</b> Pressione lavoro	Up to 5800 psi / Fino a 400 bar
<b>Working Temperature</b> Temperatura lavoro	140°C - 280°F *
<b>Inlet thread size</b> Connessione Ingresso	1/2" M
<b>Outlet thread size</b> Connessione uscita	1/2" F
<b>Weight</b> Peso	18 kg
<b>Packing size</b> Dimensione imballo	280x600x550 mm
<b>Raw material sides and roll</b> Materiali costruttivi rullo e fiancate	Carbon Steel Acciaio al carbonio
<b>Raw material shaft</b> Materiali costruttivi perno	Carbon Steel Acciaio al carbonio
<b>Raw material swivel joint</b> Materiali costruttivi giunto	AISI 303
<b>Raw material main spring</b> Materiale molla principale	Carbon Steel Acciaio al carbonio
<b>Can be used to transfer</b> Adatto all'utilizzo con	Water / Acqua
<b>Included Accessories</b> Accessori inclusi	Hose bumper (1/4", 3/8" o 1/2") and nipple (3/8" o 1/2") Palla finecorsa (1/4", 3/8" o 1/2") e nipplo (3/8" o 1/2")

\* This product has been designed for continuous use at a water temperature of 90°C-195°F. It can resist at the max temperature of 140°C - 280°F only for a short period of time. Not suitable for use with steam. Report appropriate area «Steam».

\* Il prodotto è stato progettato per un utilizzo continuo ad una temperatura dell'acqua di 90°C -195°F. Può resistere solo per brevi periodi alla temperatura massima di 140°C -280°F. Non adatto all'utilizzo con vapore. Consultare apposita area «Vapore».

Steam



# HR1100 400

EXPLODED VIEW > ESPLOSO

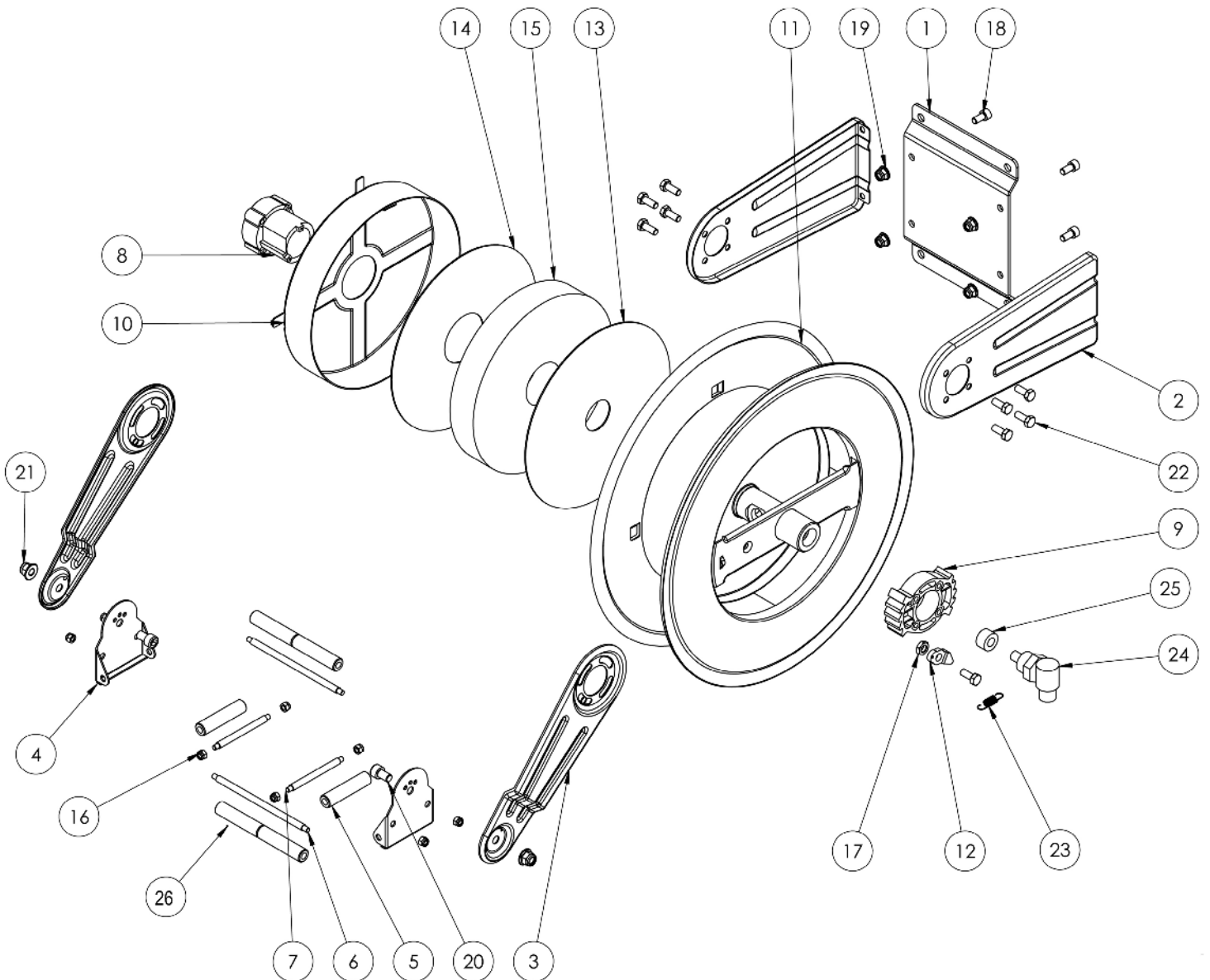

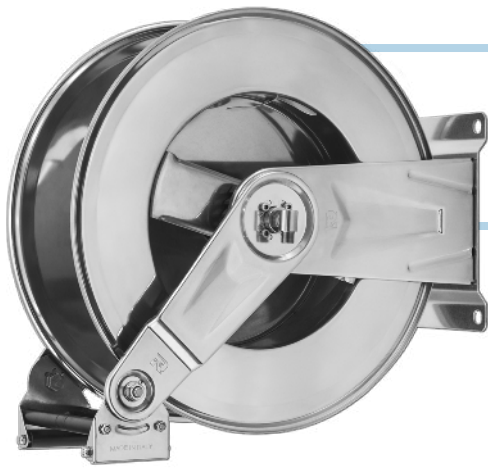

# HR1100 400

EXPLODED VIEW › ESPLOSO

POS	Description and quantity / Descrizione e quantità	HR 1100 400		HR 1100 400 316		HR 1100 400 FE CA	
1	Base (1x)						
2	Side fixed arm / Fiancata fissa (2x)						
3	Mobile arm / Fiancata mobile (2x)						
4	Roller guide / Guida rullino (2x)						
5	Vertical roller / Rullino verticale (2x)						
6	Horizontal rod / Tirante orizzontale (2x)						
7	Vertical rod / Tirante verticale (2x)						
8	Plastic hub / Perno in plastica (1x)	KIT 92		KIT 92 316		KIT 92	
10	Spring case / Padellotto portamolla (1x)						
13	Plastic separator / Distanziale in plastica (1x)						
14	Plastic separator / Distanziale in plastica (1x)						
15	Main spring / Molla principale (1x)						
9	Plastic rack / Cremagliera in plastica (1x)	KIT CR 1		KIT CR 1		KIT CR 1	
11	Reel / Bobina (1x)						
12	Plastic ratchet / Salterello in plastica nudo (1x)	KIT 93	RC 10	KIT 93 316	RC 10	KIT 93	RC 10
17	Ratchet screw + nut M10 / Vite per salterello + dado M10 (1x)		RC 20		RC 20 316		RC 20
23	Ratchet spring / Molla per salterello (1x)		KIT 12		KIT 12 316		KIT 12
16	Nut M6 / Dado M6 (8x)						
18	Screw M8 / Vite M8 (4x)						
19	Nut M8 / Dado M8 (4x)						
20	Screw M10 / Vite M10 (2x)						
21	Nut M10 / Dado M10 (2x)						
22	Screw M8 / Vite M8 (8x)						
24	Swivel joint / Giunto girevole (1x)	4962 400		4960 1/2" 400		4962 400	
25	Bushing seal / Boccola tenuta (1x)		KIT 400		KIT400 316		KIT 400
26	Horizontal roller / Rullino orizzontale (2x)						



# HR1100 400

DIMENSIONAL DRAWING › DISEGNO DIMENSIONALE

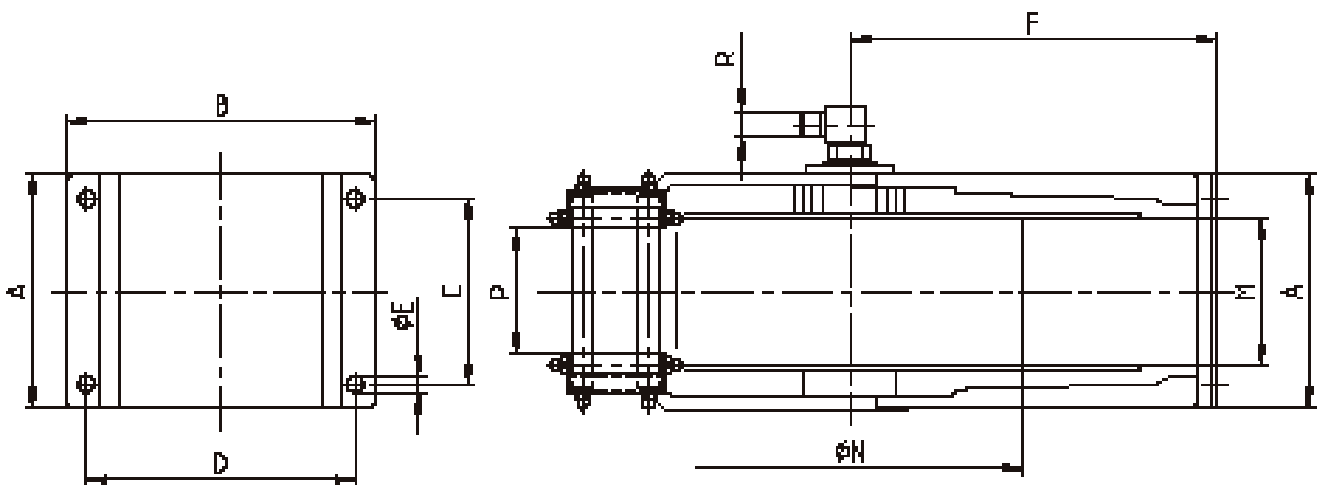
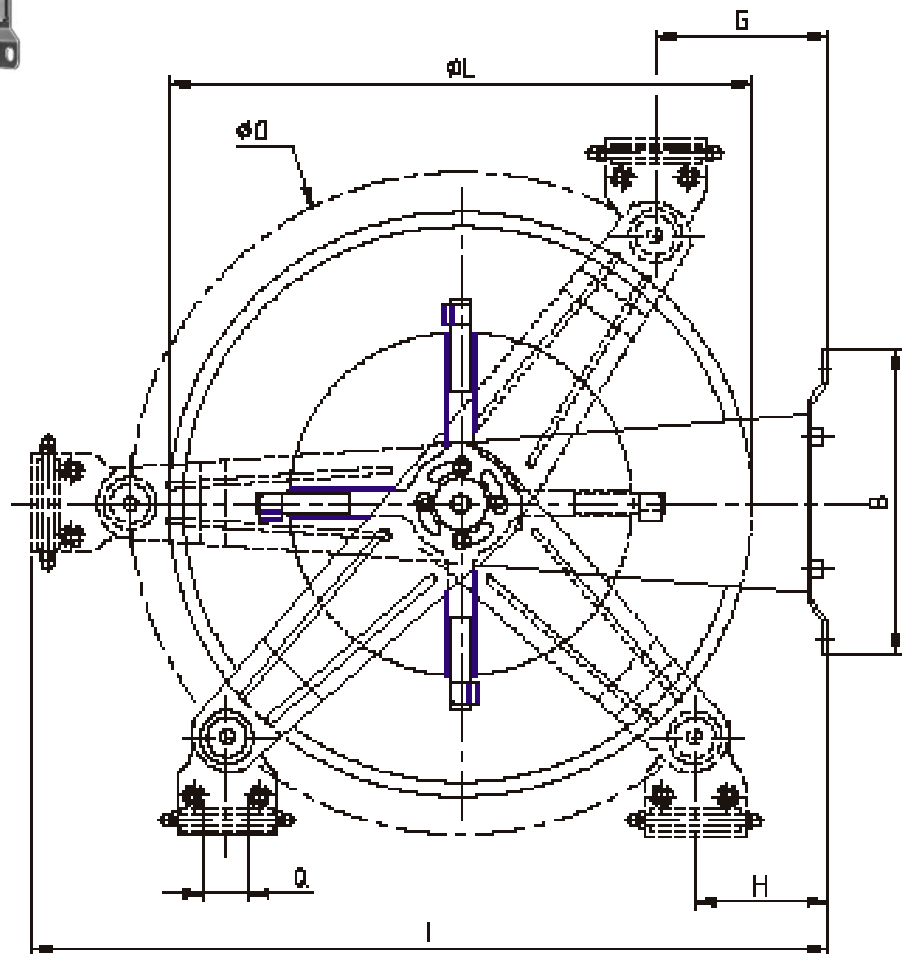

ART.	A	B	C	D	E	F	G	H	I	L	M	N	O	P	Q	R
HR1100 400	210 mm	235 mm	180 mm	204 mm	13 mm	262 mm	50 mm	50 mm	560 mm	430 mm	145 mm	260 mm	460 mm	120 mm	40 mm	1/2"



# HR1100 400



## INCLUDED ACCESSORIES › ACCESSORI INCLUSI

HOSE REEL AVVOLGITUBO	HOSE BUMPER FERMATUBO	NIPPLE NIPPLO	SWIVEL JOINT GIUNTO GIREVOLE	
HR 1100 400	4944 	4908	4962 400	
HR 1100 400 316		4908 - 316	4962 400 - 316	
HR 1100 400 FE		4908 - FE 	4962 400	
HR 1100 400 CA				

## OPTIONAL ACCESSORIES › ACCESSORI OPTIONAL

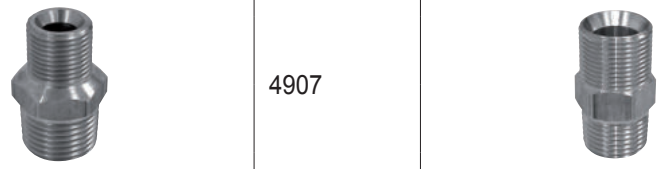
HOSE REEL AVVOLGITUBO	HOSE BUMPER FERMATUBO
HR 1100 400	
HR 1100 400 316	
HR 1100 400 FE	
HR 1100 400 CA	

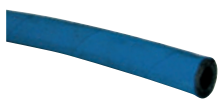
HOSE REEL AVVOLGITUBO	NIPPLE NIPPLO
HR 1100 400	
HR 1100 400 316	
HR 1100 400 FE	
HR 1100 400 CA	

HOSE TUBO	STANDARD FITTING RACCORDO STANDARD	OPTION OPZIONE
ON REQUEST SU RICHIESTA 	4932 3/8"	
ON REQUEST SU RICHIESTA 	4932 1/2"	