



AV4500 BK

WHY RAMEX HOSE REELS › PERCHÈ UN AVVOLGITUBO RAMEX

■ SAVE TIME	■ RISPARMIO DI TEMPO
■ SAVE MONEY	■ RISPARMIO DI DENARO
■ INCREASED SAFETY	■ SICUREZZA SUL LAVORO
■ LONG HOSE DURABILITY	■ INCREMENTA LA DURATA DEL TUBO
■ EFFICIENCY IN DAILY WORK	■ EFFICIENZA NEL LAVORO QUOTIDIANO
■ 100% MADE IN ITALY	■ MADE IN ITALY 100%

WHERE TO USE › DOVE UTILIZZARLO



PROPER USE › CORRETTO UTILIZZO



1



2



3



4



5



6

video





AV4500 BK

TECHNICAL FEATURES › CARATTERISTICHE TECNICHE

AV4500 BK AISI 304

Admitted diameters Diametri ammessi	1/2"
Hose lenght in meters Lunghezza tubo	Up to 131.2 ft 1/2" Fino a 40 mt 1/2"
Working pressure Pressione lavoro	Up to 2900 psi / Fino a 200 bar
Working Temperature Temperatura lavoro	140°C - 280°F *
Inlet thread size Connessione Ingresso	1/2" M
Outlet thread size Connessione uscita	1/2" F
Weight Peso	37,7 kg
Packing size Dimensione imballo	470x550x650 mm
Raw material sides and roll Materiali costruttivi rullo e fiancate	AISI 304
Raw material shaft and swivel joint Materiali costruttivi perno e giunto	AISI 303
Raw material main spring Materiale molla principale	Carbon Steel Acciaio al carbonio
Can be used to transfer Adatto all'utilizzo con	Air Water Chemical Aria Acqua Prodotti Chimici
Included Accessories Accessori inclusi	Hose bumper (1/2") and nipple (1/2") Palla finecorsa (1/2") e nipplo (1/2")

AV4500 BK AISI 316

Admitted diameters Diametri ammessi	1/2"
Hose lenght in meters Lunghezza tubo	Up to 131.2 ft 1/2" Fino a 40 mt 1/2"
Working pressure Pressione lavoro	Up to 2900 psi / Fino a 200 bar
Working Temperature Temperatura lavoro	140°C - 280°F *
Inlet thread size Connessione Ingresso	1/2" M
Outlet thread size Connessione uscita	1/2" F
Weight Peso	37,7 kg
Packing size Dimensione imballo	470x550x650 mm
Raw material sides and roll Materiali costruttivi rullo e fiancate	AISI 316
Raw material shaft and swivel joint Materiali costruttivi perno e giunto	AISI 316
Raw material main spring Materiale molla principale	Carbon Steel Acciaio al carbonio
Can be used to transfer Adatto all'utilizzo con	Air Water Chemical Aria Acqua Prodotti Chimici
Included Accessories Accessori inclusi	Hose bumper (1/2") and nipple (1/2") Palla finecorsa (1/2") e nipplo (1/2")

AV4500 BK FE

Admitted diameters Diametri ammessi	1/2"
Hose lenght in meters Lunghezza tubo	Up to 131.2 ft 1/2" Fino a 40 mt 1/2"
Working pressure Pressione lavoro	Up to 2900 psi / Fino a 200 bar
Working Temperature Temperatura lavoro	140°C - 280°F *
Inlet thread size Connessione Ingresso	1/2" M
Outlet thread size Connessione uscita	1/2" F
Weight Peso	37,7 kg
Packing size Dimensione imballo	470x550x650 mm
Raw material sides and roll Materiali costruttivi rullo e fiancate	Carbon Steel Acciaio al carbonio
Raw material shaft and swivel joint Materiali costruttivi perno e giunto	Carbon Steel Acciaio al carbonio
Raw material main spring Materiale molla principale	Carbon Steel Acciaio al carbonio
Can be used to transfer Adatto all'utilizzo con	Air Water / Aria Acqua On request Oil Grease Su richiesta Olio Grasso
Included Accessories Accessori inclusi	Hose bumper (1/2") and nipple (1/2") Palla finecorsa (1/2") e nipplo (1/2")

AV4500 BK CA

Admitted diameters Diametri ammessi	1/2"
Hose lenght in meters Lunghezza tubo	Up to 131.2 ft 1/2" Fino a 40 mt 1/2"
Working pressure Pressione lavoro	Up to 2900 psi / Fino a 200 bar
Working Temperature Temperatura lavoro	140°C - 280°F *
Inlet thread size Connessione Ingresso	1/2" M
Outlet thread size Connessione uscita	1/2" F
Weight Peso	37,7 kg
Packing size Dimensione imballo	470x550x650 mm
Raw material sides and roll Materiali costruttivi rullo e fiancate	Carbon Steel Acciaio al carbonio
Raw material shaft and swivel joint Materiali costruttivi perno e giunto	Carbon Steel Acciaio al carbonio
Raw material main spring Materiale molla principale	Carbon Steel Acciaio al carbonio
Can be used to transfer Adatto all'utilizzo con	Air Water / Aria Acqua On request Oil Grease Su richiesta Olio Grasso
Included Accessories Accessori inclusi	Hose bumper (1/2") and nipple (1/2") Palla finecorsa (1/2") e nipplo (1/2")

* This product has been designed for continuous use at a water temperature of 90°C-195°F. It can resist at the max temperature of 140°C - 280°F only for a short period of time. Not suitable for use with steam. Report appropriate area «Steam».

* Il prodotto è stato progettato per un utilizzo continuo ad una temperatura dell'acqua di 90°C -195°F. Può resistere solo per brevi periodi alla temperatura massima di 140°C -280°F. Non adatto all'utilizzo con vapore. Consultare apposita area «Vapore».

Steam



AV4500 BK

SAFETY SLOW RETRACTION › SISTEMA FRENANTE DI SICUREZZA

SLOW RETRACTION SYSTEM BK HOSE REEL (SAFETY BRAKE) ASSEMBLY

A new innovative system to reduce the speed of uncontrolled automatic hose reel. Just ask to receive hose reel with "SLOW RETRACTION SAFETY BRAKE SYSTEM BK", it will be equipped with an innovative system that will reduce the retracting speed of the reel.

- 1** *Dismount the external frame adapter unscrewing the four screws.*



- 2** *Take out external frame over and the EPDM cover.*





AV4500 BK

SAFETY SLOW RETRACTION › SISTEMA FRENANTE DI SICUREZZA

3

You receive the brake already tested! In case you absolutely need to adjust the speed return of the hose just turn, everytime only few degree, the small screw with hexagonal seat (indicated by arrow). Make a test after every small turn. In case of accidental dismounting of the regulation of screw and leaking of oil, the system must return to RAMEX to be fixed up.

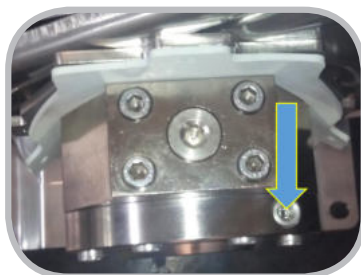

4

Reassembling external frame over on the EPDM cover. Tight the four screws.





AV4500 BK

EXPLODED VIEW › ESPLOSO

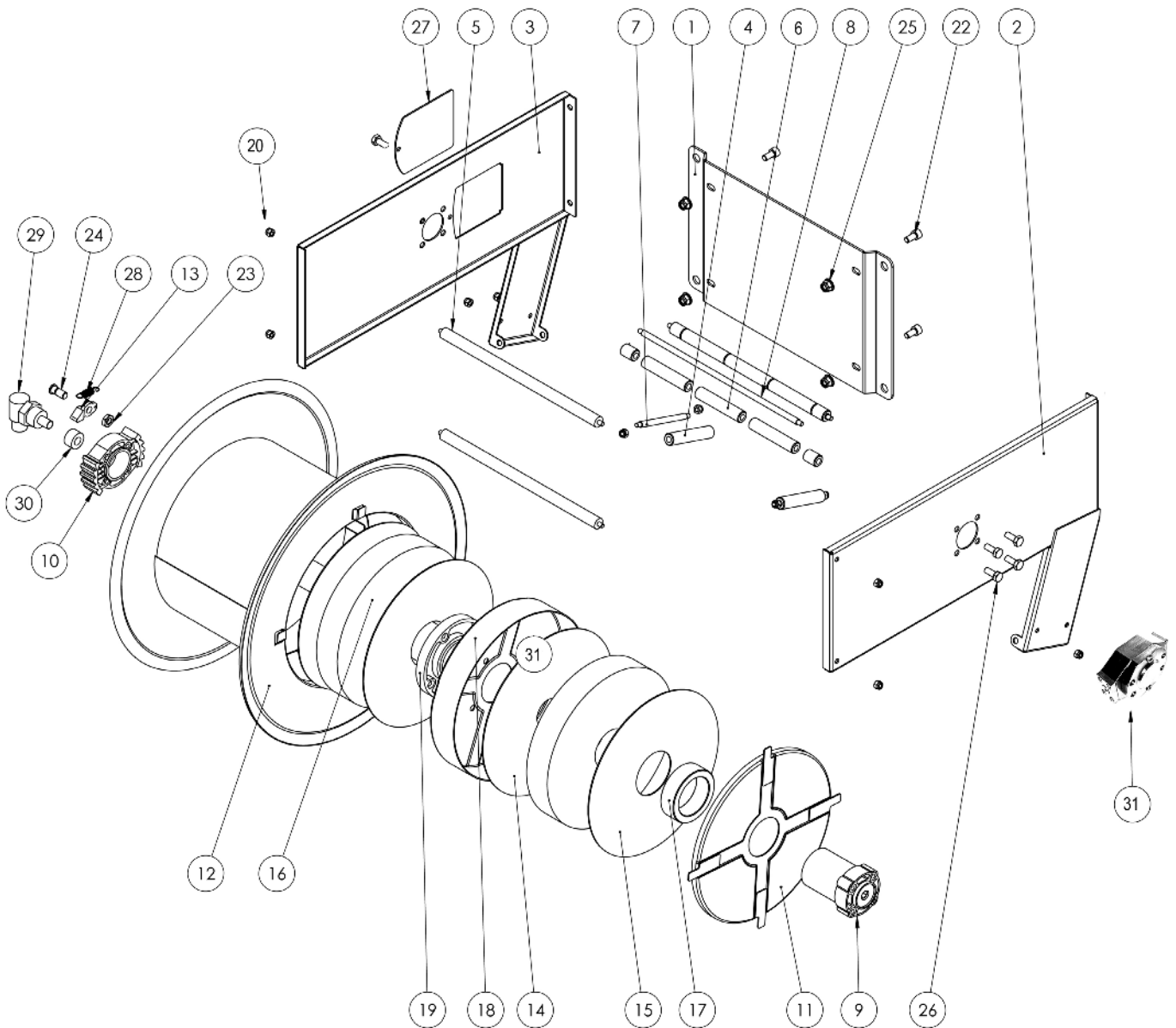



AV4500 BK

EXPLODED VIEW › ESPLOSO

POS	Description and quantity / Descrizione e quantità	AV 4500 BK	AV 4500 BK 316	AV 4500 BK FE CA			
1	Base (1x)						
2	Side without open / Fiancata senza apertura (1x)						
3	Side with open / Fiancata con apertura (1x)						
4	Vertical roller / Rullino verticale (2x)						
5	Horizontal rod large / Tirante orizzontale grande (2x)						
6	Horizontal roller / Rullino orizzontale (2x)						
7	Vertical rod / Tirante verticale (2x)						
8	Horizontal rod small / Tirante orizzontale piccolo (2x)						
10	Plastic rack / Cremagliera in plastica (1x)	KIT CR 1	KIT CR 1	KIT CR 1			
9	Plastic external hub / Perno in plastica esterno (1x)	KIT 96	KIT 96 316	KIT 96			
11	Spring cover / Copertura per molla (1x)						
14	Plastic separator / Distanziale in plastica (2x)						
15	Plastic separator / Distanziale in plastica (2x)						
16	Main spring / Molla principale (2x)						
17	Plastic ring / Anello in plastica (1x)						
18	Spring support / Supporto molla (1x)						
19	Plastic internal hub / Perno in plastica interno (1x)						
31	Screw for internal hub / Vite per perno interno (4x)						
12	Reel / Bobina (1x)						
20	Nut M6 / Dado M6 (12x)						
22	Screw M8 / Vite M8 (4x)						
25	Nut M8 / Dado M8 (4x)						
26	Screw M8 / Vite M8 (8x)						
27	Plastic closing + screw / Chiusura in plastica + vite (1x)						
13	Plastic ratchet / Salterello in plastica nudo (1x)	KIT 93	KIT 93 316	KIT 93	RC 10		
23	Nut for ratchet screw / Dado per vite salterello (1x)				RC 20	RC 20 316	RC 20
24	Ratchet screw / Vite per salterello (1x)				KIT 12	KIT 12 316	KIT 12
28	Ratchet spring / Molla per salterello (1x)						
29	Swivel joint / Giunto girevole (1x)	4962	4960 1/2"	4961			
30	Bushing seal / Boccola tenuta (1x)				KIT10 NEW	KIT10 NEW 316	KIT10
31	Braking system (including screws, special rod and flange) Sistema frenante (viti, tirante speciale e flangia inclusi) (1x)						



AV4500 BK

DIMENSIONAL DRAWING > DISEGNO DIMENSIONALE

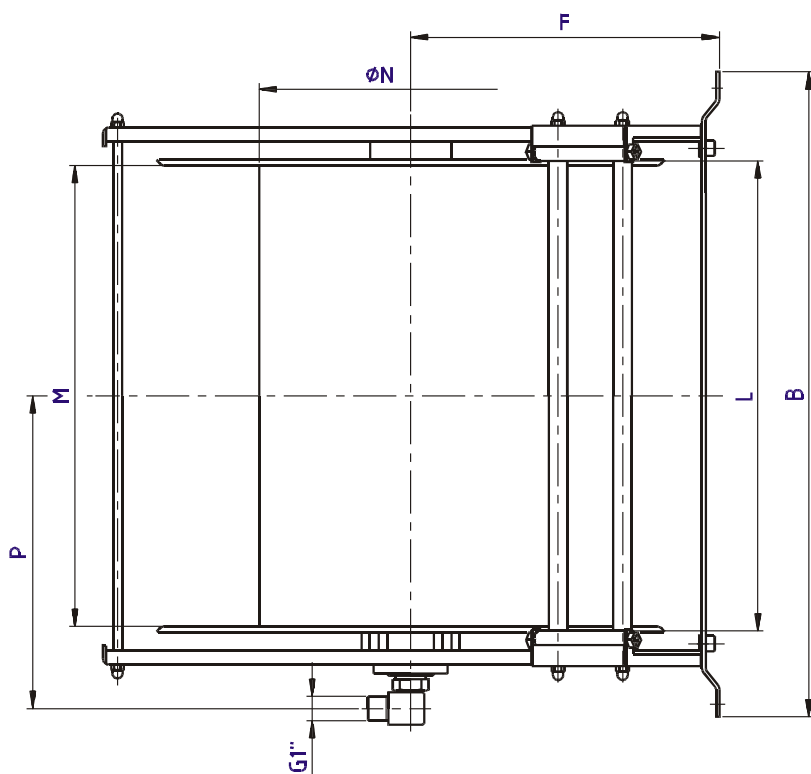
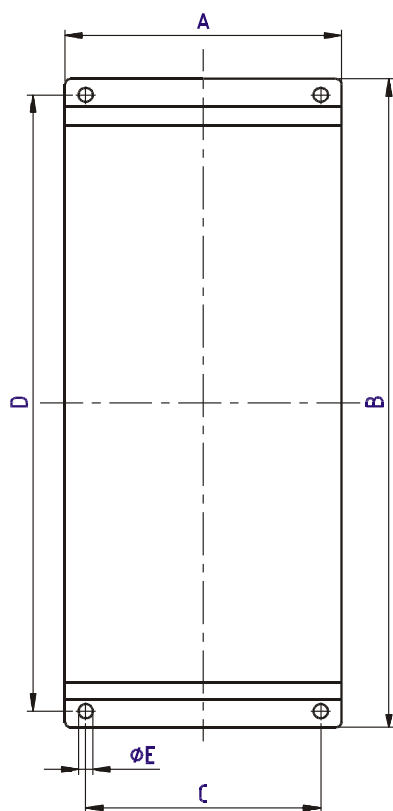
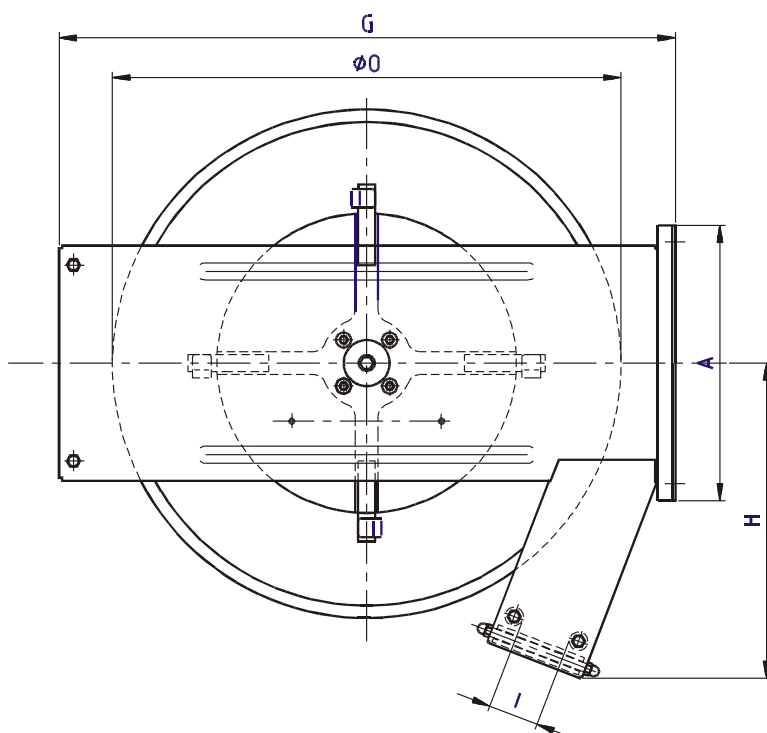

ART.	A	B	C	D	E	F	G	H	I	L	M	N	O
AV4500 BK	234 mm	440 mm	205 mm	410 mm	13 mm	270 mm	530 mm	290 mm	45 mm	303 mm	290 mm	260 mm	430 mm



AV4500 BK

INCLUDED ACCESSORIES › ACCESSORI INCLUSI

HOSE REEL AVVOLGITUBO	HOSE BUMPER FERMATUBO	NIPPLE NIPPLIO	SWIVEL JOINT GIUNTO GIREVOLE	
AV 4500 BK		4908	4962	
AV 4500 BK 316		4908 - 316	4962 - 316	
AV 4500 BK FE		4908 - FE		
AV 4500 BK CA				

OPTIONAL ACCESSORIES › ACCESSORI OPTIONAL

HOSE REEL AVVOLGITUBO	HOSE BUMPER FERMATUBO	GOOSENECK BEND CURVA
AV 4500 BK	   	
AV 4500 BK 316		
AV 4500 BK FE		
AV 4500 BK CA		

HOSE REEL AVVOLGITUBO	NIPPLE NIPPLIO
AV 4500 BK	
AV 4500 BK 316	
AV 4500 BK FE	
AV 4500 BK CA	

HOSE TUBO	STANDARD FITTING RACCORDO STANDARD	OPTION OPZIONE
43 1/2" 		
45 1/2" 		
18 3/8" 		
18 1/2" 		
61 1/2" 		
67 1/2" 		