

HR3511 WE

WHY RAMEX HOSE REELS › PERCHÈ UN AVVOLGITUBO RAMEX

■ SAVE TIME	■ RISPARMIO DI TEMPO
■ SAVE MONEY	■ RISPARMIO DI DENARO
■ INCREASED SAFETY	■ SICUREZZA SUL LAVORO
■ LONG HOSE DURABILITY	■ INCREMENTA LA DURATA DEL TUBO
■ EFFICIENCY IN DAILY WORK	■ EFFICIENZA NEL LAVORO QUOTIDIANO
■ 100% MADE IN ITALY	■ MADE IN ITALY 100%

WHERE TO USE › DOVE UTILIZZARLO



PROPER USE › CORRETTO UTILIZZO



1



2



3



4



5



6

video

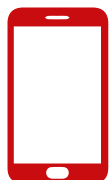

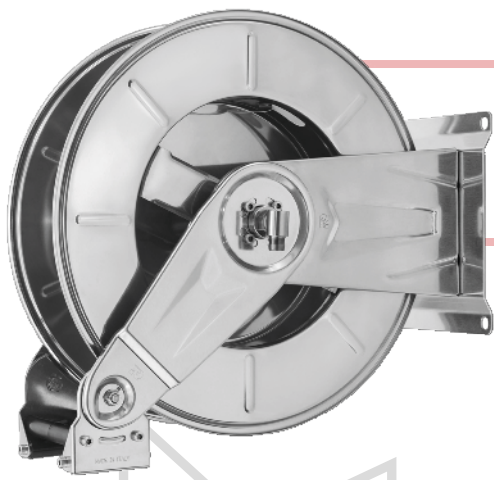

HR3511 WE

TECHNICAL FEATURES › CARATTERISTICHE TECNICHE

HR3511 WE AISI 304

Admitted diameters Diametri ammessi	5/16" (8+8)
Hose lenght in meters Lunghezza tubo	Up to 115 ft 5/16" Fino a 35 mt 5/16"
Working pressure Pressione lavoro	Up to 290 psi / Fino a 20 bar
Working Temperature Temperatura lavoro	176°F / 80°C
Inlet thread size Connessione Ingresso	3/8"
Outlet thread size Connessione uscita	3/8"
Weight Peso	28 kg
Packing size Dimensione imballo	340x610x640 mm
Raw material sides and roll Materiali costruttivi rullo e fiancate	Carbon Steel Acciaio al carbonio
Raw material shaft and swivel joint Materiali costruttivi perno e giunto	Brass Ottone
Raw material main spring Materiale molla principale	Carbon Steel Acciaio al carbonio
Can be used to transfer Adatto all'utilizzo con	Oxygen + acetylene Ossigeno + acetilene
Included Accessories Accessori inclusi	Hose bumper Tampone finecorsa

HR3511 WE FE

Admitted diameters Diametri ammessi	5/16" (8+8)
Hose lenght in meters Lunghezza tubo	Up to 115 ft 5/16" Fino a 35 mt 5/16"
Working pressure Pressione lavoro	Up to 290 psi / Fino a 20 bar
Working Temperature Temperatura lavoro	176°F / 80°C
Inlet thread size Connessione Ingresso	3/8"
Outlet thread size Connessione uscita	3/8"
Weight Peso	28 kg
Packing size Dimensione imballo	340x610x640 mm
Raw material sides and roll Materiali costruttivi rullo e fiancate	Carbon Steel Acciaio al carbonio
Raw material shaft and swivel joint Materiali costruttivi perno e giunto	Brass Ottone
Raw material main spring Materiale molla principale	Carbon Steel Acciaio al carbonio
Can be used to transfer Adatto all'utilizzo con	Oxygen + acetylene Ossigeno + acetilene
Included Accessories Accessori inclusi	Hose bumper Tampone finecorsa

Rammer

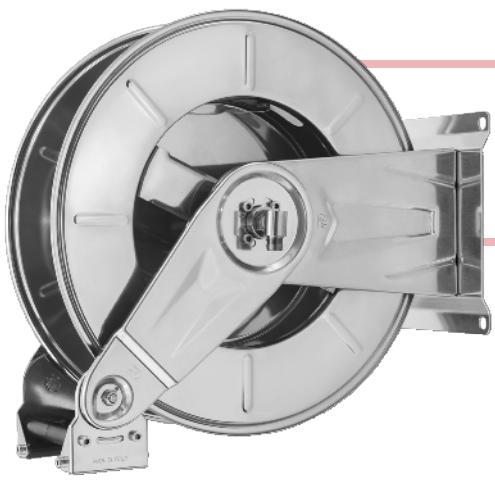

HR3511 WE

EXPLODED VIEW › ESPLOSO

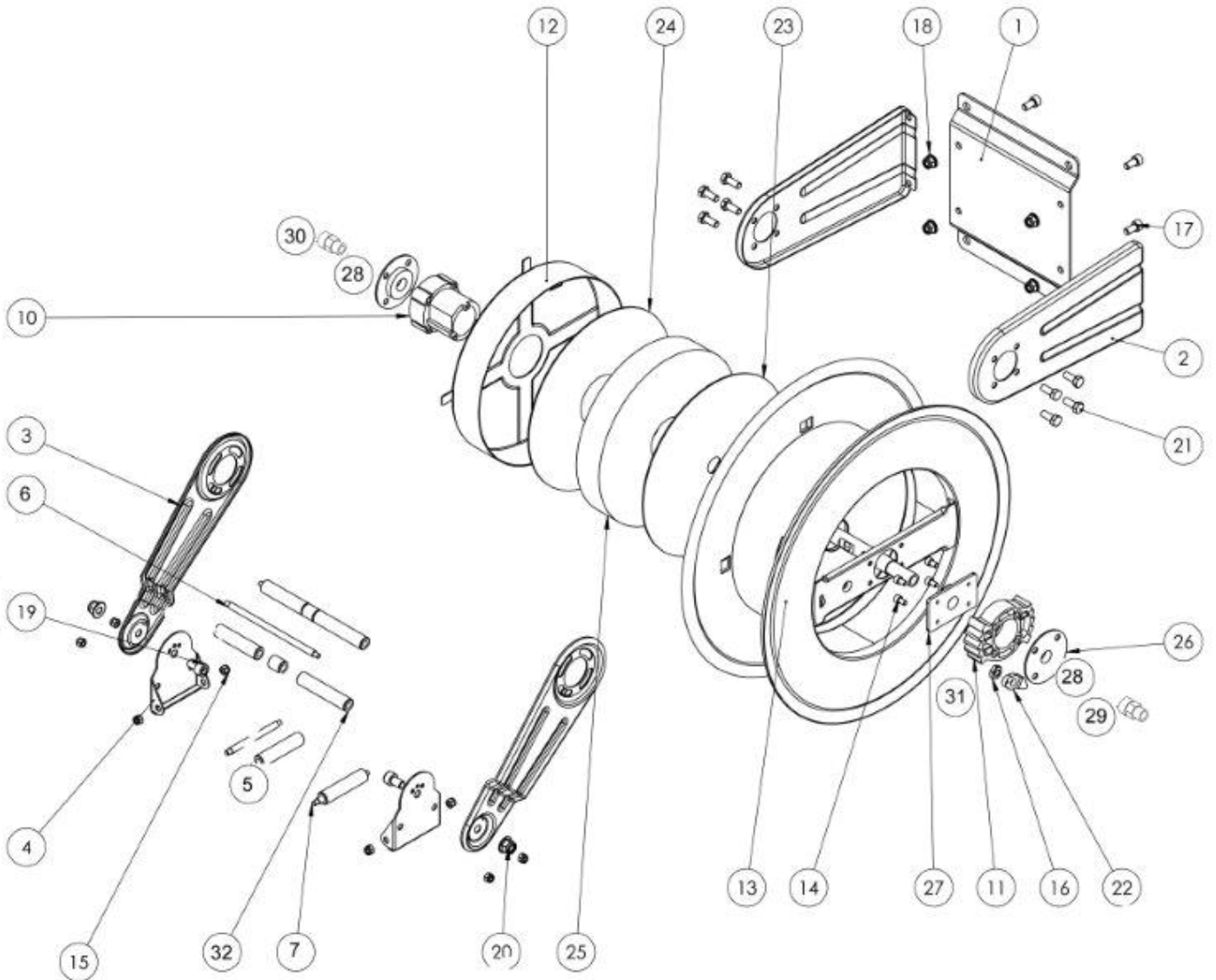

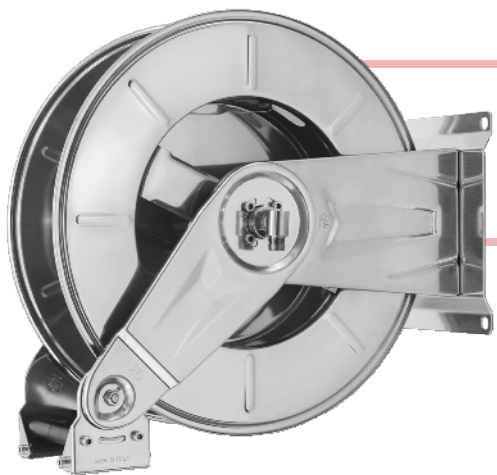

HR3511 WE

EXPLODED VIEW / ESPLOSO

POS	Description and quantity / Descrizione e quantità	HR 3511 WE		HR 3511 WE FE CA	
1	Base (1x)				
2	Side fixed arm / Fiancata fissa (2x)				
3	Mobile arm / Fiancata mobile (2x)				
4	Roller guide / Guida rullino (2x)				
5	Vertical roller / Rullino verticale (2x)				
6	Horizontal rod / Tirante orizzontale (2x)				
7	Vertical rod / Tirante verticale (2x)				
10	Plastic hub / Perno in plastica (1x)	KIT 94 WE		KIT 94 WE	
12	Spring case / Padellotto portamolla (1x)				
23	Plastic separator / Distanziale in plastica (1x)				
24	Plastic separator / Distanziale in plastica (1x)				
25	Main spring / Molla principale (1x)				
11	Plastic rack / Cremagliera in plastica (1x)	KIT CR 1		KIT CR 1	
13	Reel / Bobina (1x)				
22	Plastic ratchet / Salterello in plastica nudo (1x)	KIT 93	RC 10	KIT 93	RC 10
16	Ratchet screw + nut M10 / Vite per salterello + dado M10 (1x)		RC 20		RC 20
31	Ratchet spring / Molla per salterello (1x)		KIT 12		KIT 12
14	Screw / Vite (4x)				
15	Nut / Dado (8x)				
17	Screw / Vite (4x)				
18	Nut / Dado (4x)				
19	Screw / Vite (2x)				
20	Nut / Dado (2x)				
21	Screw / Vite (8x)				
26	Support / Supporto (2x)				
27	Support / Supporto (1x)				
28	Washer / Rondella (2x)				
29	Oxygen Swivel joint / Giunto girevole - Ossigeno (1x)		4991		4991
30	Gas Swivel joint / Giunto girevole - Gas (1x)		4992		4992
32	Horizontal roller / Rullino orizzontale (2x)				

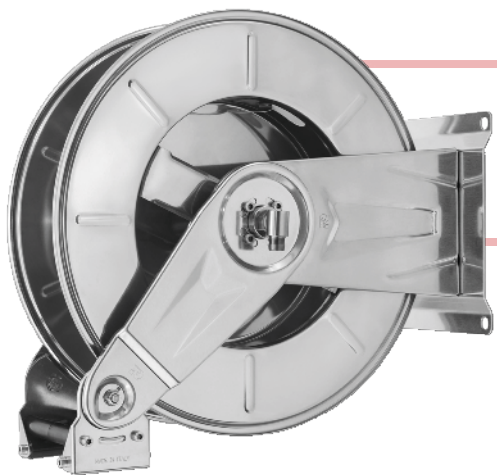

HR3511 WE

DIMENSIONAL DRAWING › DISEGNO DIMENSIONALE

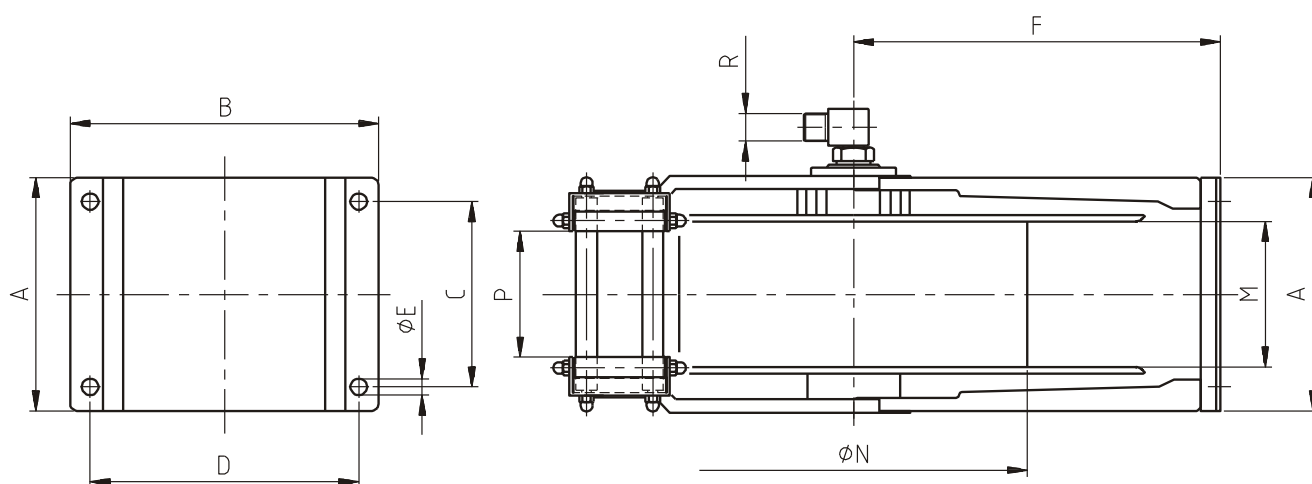
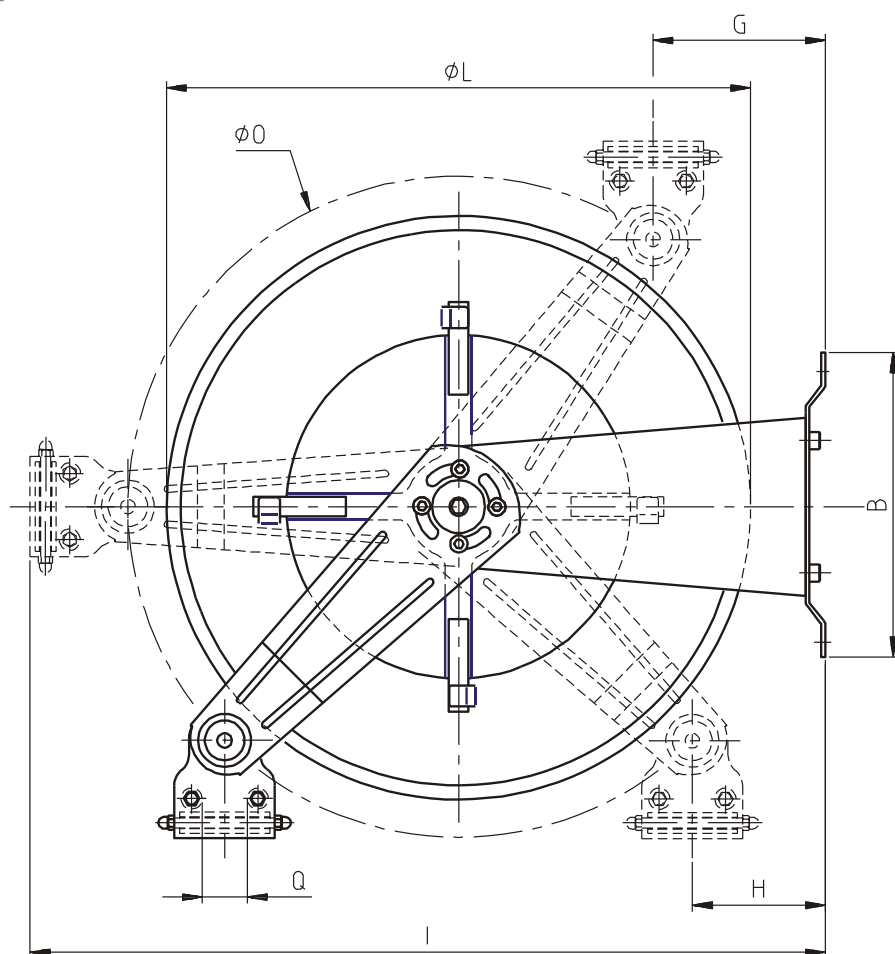



ART.	A	B	C	D	E	F	G	H	I	L	M	N	O	P	Q
HR 3511 WE	310 mm	295 mm	280 mm	263 mm	13 mm	315 mm	120 mm	107 mm	700 mm	540 mm	145 mm	310 mm	580 mm	105 mm	43 mm



HR3511 WE

INCLUDED ACCESSORIES › ACCESSORI INCLUSI

HOSE REEL AVVOLGITUBO	HOSE BUMPER TAMPONE	SWIVEL JOINT GIUNTO GIREVOLE	
HR 3511 WE		4991	
HR 3511 WE FE		4992	

OPTIONAL ACCESSORIES › ACCESSORI OPTIONAL

HOSE TUBO
66 5/16" 