

# HR1111 WE

## WHY RAMEX HOSE REELS › PERCHÈ UN AVVOLGITUBO RAMEX

■ SAVE TIME	■ RISPARMIO DI TEMPO
■ SAVE MONEY	■ RISPARMIO DI DENARO
■ INCREASED SAFETY	■ SICUREZZA SUL LAVORO
■ LONG HOSE DURABILITY	■ INCREMENTA LA DURATA DEL TUBO
■ EFFICIENCY IN DAILY WORK	■ EFFICIENZA NEL LAVORO QUOTIDIANO
■ 100% MADE IN ITALY	■ MADE IN ITALY 100%

## WHERE TO USE › DOVE UTILIZZARLO



## PROPER USE › CORRETTO UTILIZZO



1



2



3



4



5



6

video





# HR1111 WE

## TECHNICAL FEATURES › CARATTERISTICHE TECNICHE

### HR1111 WE AISI 304

<b>Admitted diameters</b> Diametri ammessi	5/16" (8+8)
<b>Hose lenght in meters</b> Lunghezza tubo	Up to 66 ft 5/16" Fino a 20 mt 5/16"
<b>Working pressure</b> Pressione lavoro	Up to 290 psi / Fino a 20 bar
<b>Working Temperature</b> Temperatura lavoro	176°F / 80°C
<b>Inlet thread size</b> Connessione Ingresso	3/8"
<b>Outlet thread size</b> Connessione uscita	3/8"
<b>Weight</b> Peso	18 kg
<b>Packing size</b> Dimensione imballo	280x610x540 mm
<b>Raw material sides and roll</b> Materiali costruttivi rullo e fiancate	Carbon Steel Acciaio al carbonio
<b>Raw material shaft and swivel joint</b> Materiali costruttivi perno e giunto	Brass Ottone
<b>Raw material main spring</b> Materiale molla principale	Carbon Steel Acciaio al carbonio
<b>Can be used to transfer</b> Adatto all'utilizzo con	Oxygen + acetylene Ossigeno + acetilene
<b>Included Accessories</b> Accessori inclusi	Hose bumper Tampone finecorsa

### HR1111 WE FE

<b>Admitted diameters</b> Diametri ammessi	5/16" (8+8)
<b>Hose lenght in meters</b> Lunghezza tubo	Up to 66 ft 5/16" Fino a 20 mt 5/16"
<b>Working pressure</b> Pressione lavoro	Up to 290 psi / Fino a 20 bar
<b>Working Temperature</b> Temperatura lavoro	176°F / 80°C
<b>Inlet thread size</b> Connessione Ingresso	3/8"
<b>Outlet thread size</b> Connessione uscita	3/8"
<b>Weight</b> Peso	18 kg
<b>Packing size</b> Dimensione imballo	280x610x540 mm
<b>Raw material sides and roll</b> Materiali costruttivi rullo e fiancate	Carbon Steel Acciaio al carbonio
<b>Raw material shaft and swivel joint</b> Materiali costruttivi perno e giunto	Brass Ottone
<b>Raw material main spring</b> Materiale molla principale	Carbon Steel Acciaio al carbonio
<b>Can be used to transfer</b> Adatto all'utilizzo con	Oxygen + acetylene Ossigeno + acetilene
<b>Included Accessories</b> Accessori inclusi	Hose bumper Tampone finecorsa

ramex



# HR1111 WE

EXPLODED VIEW › ESPLOSO

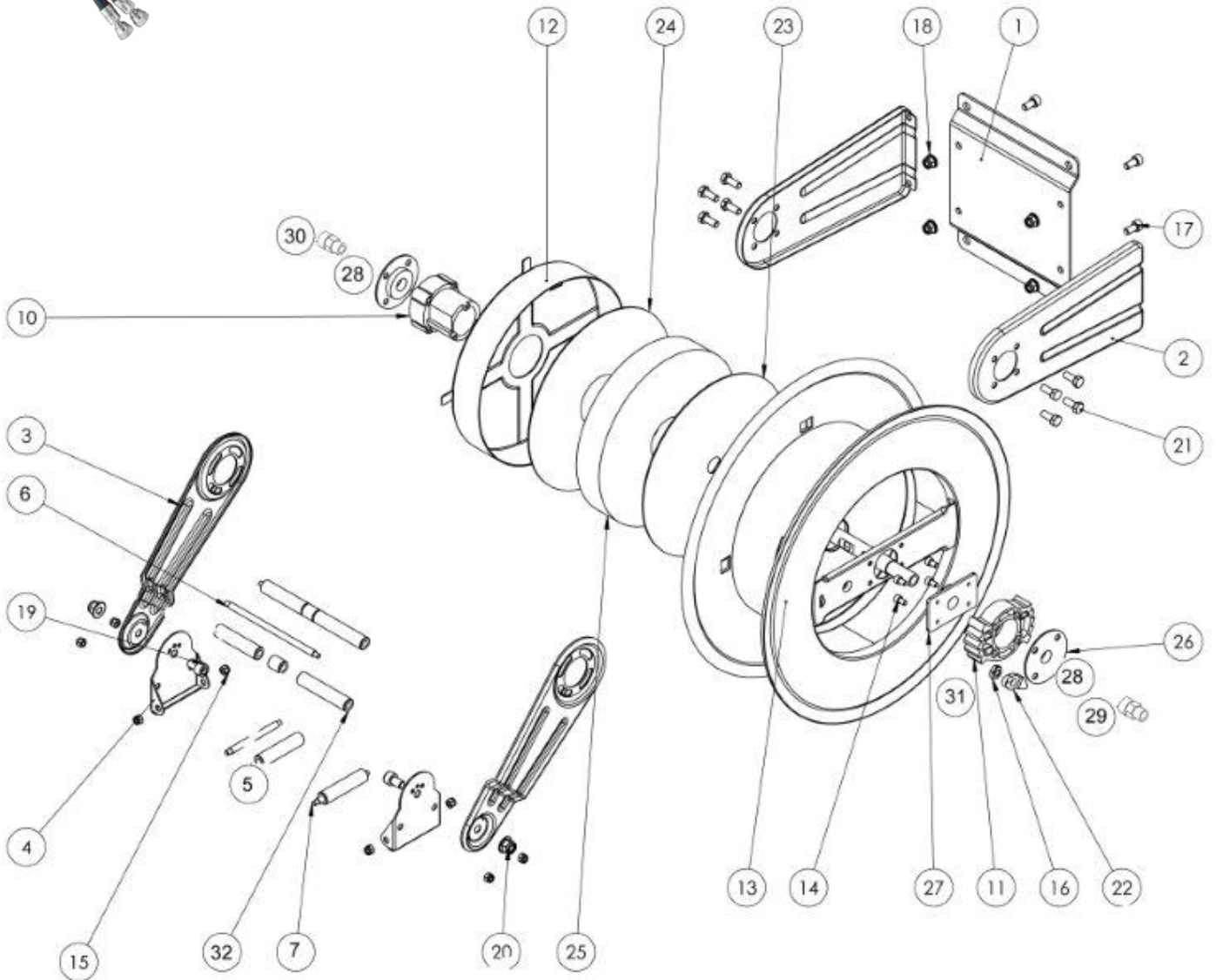

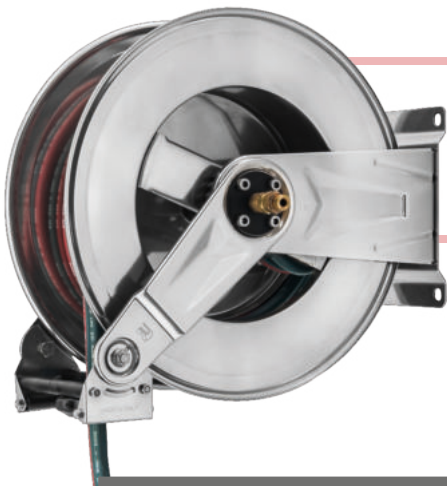

# HR1111 WE

**EXPLODED VIEW / ESPLOSO**

POS	Description and quantity / Descrizione e quantità	HR 1111 WE		HR 1111 WE FE CA	
1	Base (1x)				
2	Side fixed arm / Fiancata fissa (2x)				
3	Mobile arm / Fiancata mobile (2x)				
4	Roller guide / Guida rullino (2x)				
5	Vertical roller / Rullino verticale (2x)				
6	Horizontal rod / Tirante orizzontale (2x)				
7	Vertical rod / Tirante verticale (2x)				
10	Plastic hub / Perno in plastica (1x)	KIT 92 WE		KIT 92 WE	
12	Spring case / Padellotto portamolla (1x)				
23	Plastic separator / Distanziale in plastica (1x)				
24	Plastic separator / Distanziale in plastica (1x)				
25	Main spring / Molla principale (1x)				
11	Plastic rack / Cremagliera in plastica (1x)	KIT CR 1		KIT CR 1	
13	Reel / Bobina (1x)				
22	Plastic ratchet / Salterello in plastica nudo (1x)	KIT 93	RC 10	KIT 93	RC 10
16	Ratchet screw + nut M10 / Vite per salterello + dado M10 (1x)		RC 20		RC 20
31	Ratchet spring / Molla per salterello (1x)		KIT 12		KIT 12
14	Screw / Vite (4x)				
15	Nut / Dado (8x)				
17	Screw / Vite (4x)				
18	Nut / Dado (4x)				
19	Screw / Vite (2x)				
20	Nut / Dado (2x)				
21	Screw / Vite (8x)				
26	Support / Supporto (2x)				
27	Support / Supporto (1x)				
28	Washer / Rondella (2x)				
29	Oxygen Swivel joint / Giunto girevole - Ossigeno (1x)		4991		4991
30	Gas Swivel joint / Giunto girevole - Gas (1x)		4992		4992
32	Horizontal roller / Rullino orizzontale (2x)				



# HR1111 WE

**DIMENSIONAL DRAWING › DISEGNO DIMENSIONALE**





ART.	A	B	C	D	E	F	G	H	I	L	M	N	O	P	Q
HR 1111 WE	210 mm	235 mm	180 mm	204 mm	13 mm	262 mm	50 mm	50 mm	560 mm	430 mm	145 mm	260 mm	460 mm	120 mm	40 mm



# HR1111 WE

## INCLUDED ACCESSORIES › ACCESSORI INCLUSI

HOSE REEL AVVOLGITUBO	HOSE BUMPER TAMPONE		SWIVEL JOINT GIUNTO GIREVOLE
HR 1111 WE		4991	
HR 1111 WE FE		4992	

## OPTIONAL ACCESSORIES › ACCESSORI OPTIONAL

HOSE  
TUBO

66 5/16"

